



AXSOL



TECHNICAL AIDS

COMMUNE CHAIR

WHEELABLE



100% plastic



Easy to carry



Five-step assembly



Portable solutions for inaccessibility toilets and showers

For many handicapped people, it is especially the simple and most personal things that become the most complicated ones and those that create physical and emotional distress.

Yes, the ability to use the toilet in every place, at any time and without limitations, is not yet to be taken for granted. It is precisely from this view, that Seatarra is launching the Wheelable, a unique commode and shower chair which will enable any handicapped person to use a regular toilet stall.



Assembly in few seconds while sitting in the chair.



Easy transfer thanks to the retractable armrests.



Easily transportable thanks to its small size.



Now, handicapped people may enjoy the freedom of movement and ability to travel abroad, to visit distant family members, to sleep outside of their homes and to be independent and worry-free about accessibility issues. In short, the Wheelable wheelchair allows you to be just as you once were or as you would like to be.

Seatar's WheelAble can be fitted with a special basin to convert it into an accessible mobile toilet.

The wheelchair is available with two different seat opening widths: 17.8 cm (WheelAble small) or 20.5 cm (WheelAble standard).

Available options

DIMENSIONS :

Open :

Overall width :

48 cm

Length :

67 cm

Seat width :

41 cm

(between retractable armrests)

Seat height :

53 cm

Backrest height :

39 cm

Overall height :

92cm

Folded :

Width :

23 cm

Height :

54 cm

Length :

67cm

Weight :

11.6 kg

Capacity :

130 kg



Storage bag

REF. 820 101



Seat bottom

REF. 820 103



Bedpan

REF. 820 105

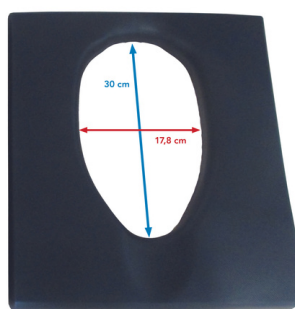

Standard seat additional

REF. 820 106

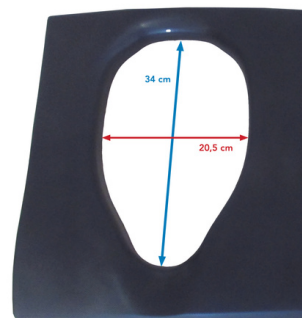

Small seat additional

REF. 820 108

FEATURES :

An armchair for indoor use, weighing 11.6 kg.

Manufacturing in plastic injection, with innovative components.

All metal parts are made of stainless steel.

Hermetic brakes.

Footrest adjustable in height.

Supplied with standard or small seat.



Footrest extension

REF. 820 140



Footrest holder

REF. 820 142

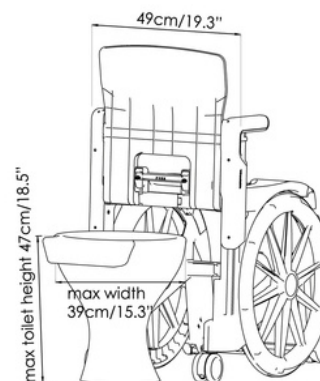
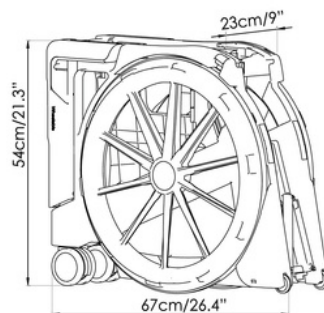

45 avenue Georges Politzer - Z.A de Trappes-Élancourt 78190 TRAPPES
Tél : +33 1 85 83 02 10 - Fax : +33 1 30 57 55 02 - Email : export@axsol.fr

www.axsol-export.eu